

Chapter 13: I/O Systems

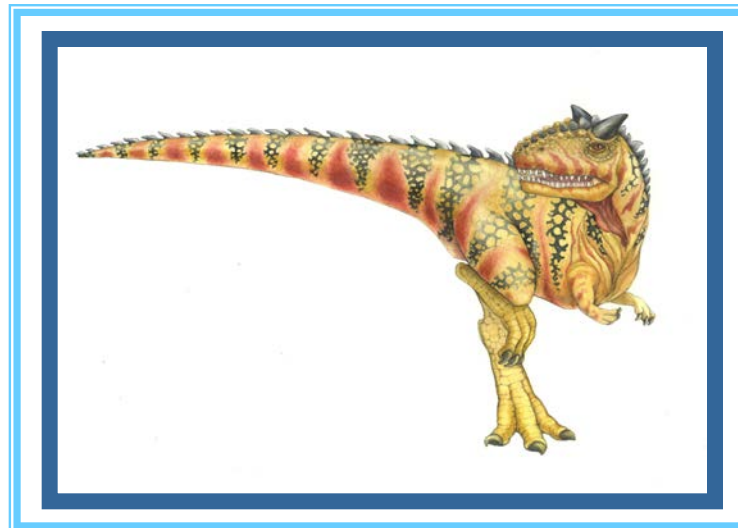



Chapter 13: I/O Systems

- Overview
- I/O Hardware
- Application I/O Interface
- Kernel I/O Subsystem
- Transforming I/O Requests to Hardware Operations
- STREAMS
- Performance





Objectives

- Explore the structure of an operating system's I/O subsystem
- Discuss the principles of I/O hardware and its complexity
- Provide details of the performance aspects of I/O hardware and software





Overview

- I/O management is a major component of operating system design and operation
 - Important aspect of computer operation
 - I/O devices vary greatly
 - Various methods to control them
 - Performance management
 - New types of devices frequent

- Ports, busses, device controllers connect to various devices

- **Device drivers** encapsulate device details
 - Present uniform device-access interface to I/O subsystem



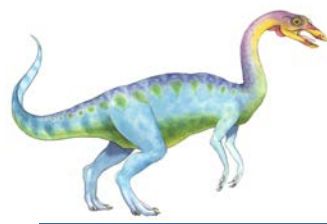

I/O Hardware

- Incredible variety of I/O devices
 - Storage
 - Transmission
 - Human-interface
- Common concepts – signals from I/O devices interface with computer
 - **Port** – connection point for device
 - **Bus - daisy chain** or shared direct access
 - ▶ **PCI** bus common in PCs and servers, PCI Express (**PCIe**)
 - ▶ **expansion bus** connects relatively slow devices
 - **Controller (host adapter)** – electronics that operate port, bus, device
 - ▶ Sometimes integrated
 - ▶ Sometimes separate circuit board (host adapter)
 - ▶ Contains processor, microcode, private memory, bus controller, etc
 - Some talk to per-device controller with bus controller, microcode, memory, etc





A Typical PC Bus Structure

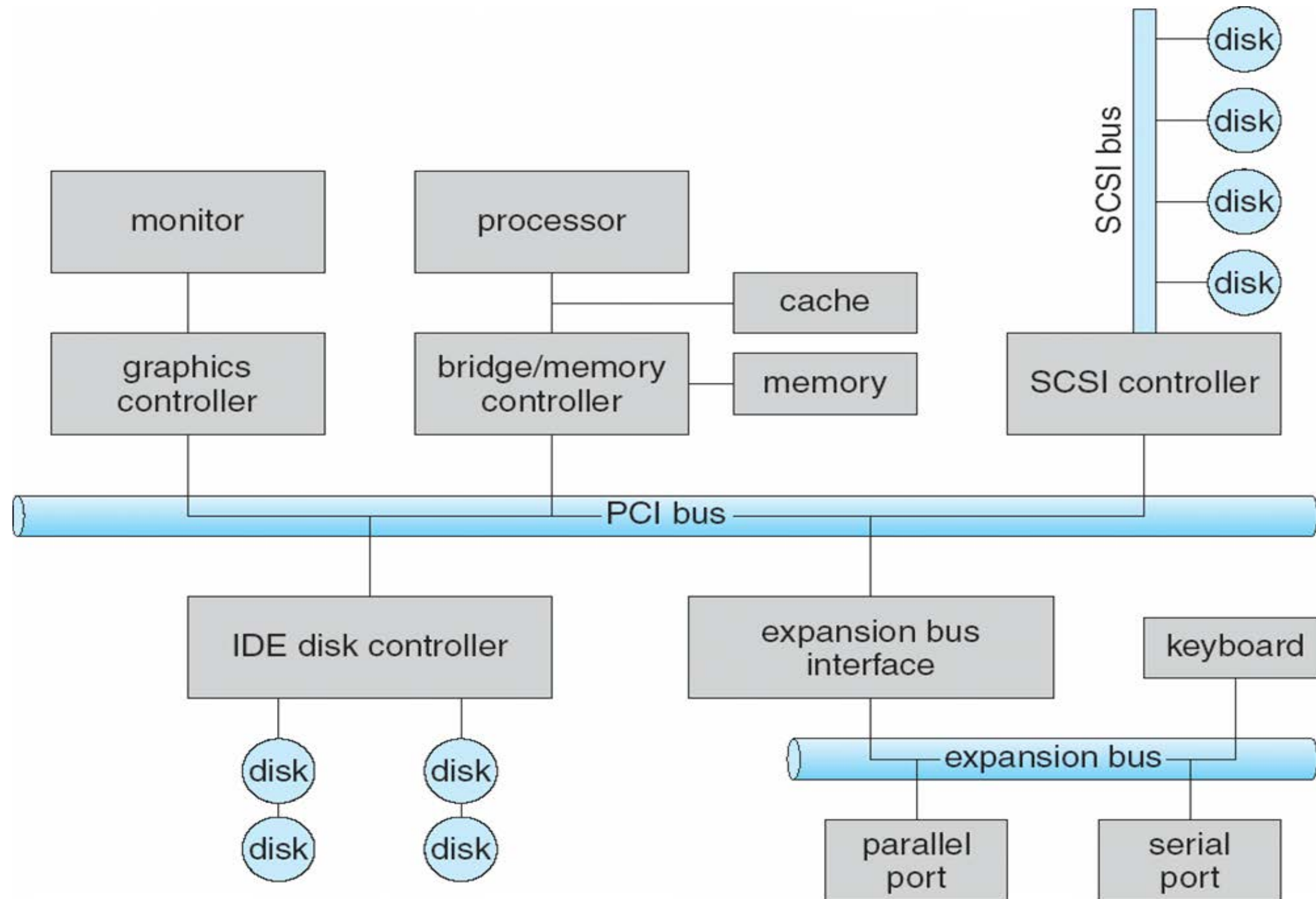



I/O Hardware (Cont.)

- I/O instructions control devices
- Devices usually have registers where device driver places commands, addresses, and data to write, or read data from registers after command execution
 - Data-in register, data-out register, status register, control register
 - Typically 1-4 bytes, or FIFO buffer
- Devices have addresses, used by
 - Direct I/O instructions
 - **Memory-mapped I/O**
 - ▶ Device data and command registers mapped to processor address space
 - ▶ Especially for large address spaces (graphics)





Device I/O Port Locations on PCs (partial)

I/O address range (hexadecimal)	device
000–00F	DMA controller
020–021	interrupt controller
040–043	timer
200–20F	game controller
2F8–2FF	serial port (secondary)
320–32F	hard-disk controller
378–37F	parallel port
3D0–3DF	graphics controller
3F0–3F7	diskette-drive controller
3F8–3FF	serial port (primary)





Polling

- For each byte of I/O
 1. Read busy bit from status register until 0
 2. Host sets read or write bit and if write copies data into data-out register
 3. Host sets command-ready bit
 4. Controller sets busy bit, executes transfer
 5. Controller clears busy bit, error bit, command-ready bit when transfer done

- Step 1 is **busy-wait** cycle to wait for I/O from device
 - Reasonable if device is fast
 - But inefficient if device slow
 - CPU switches to other tasks?
 - ▶ But if miss a cycle data overwritten / lost





Interrupts

- Polling can happen in 3 instruction cycles
 - Read status, logical-and to extract status bit, branch if not zero
 - How to be more efficient if non-zero infrequently?
- CPU **Interrupt-request line** triggered by I/O device
 - Checked by processor after each instruction
- **Interrupt handler** receives interrupts
 - **Maskable** to ignore or delay some interrupts
- **Interrupt vector** to dispatch interrupt to correct handler
 - Context switch at start and end
 - Based on priority
 - Some **nonmaskable**
 - Interrupt chaining if more than one device at same interrupt number





Interrupt-Driven I/O Cycle

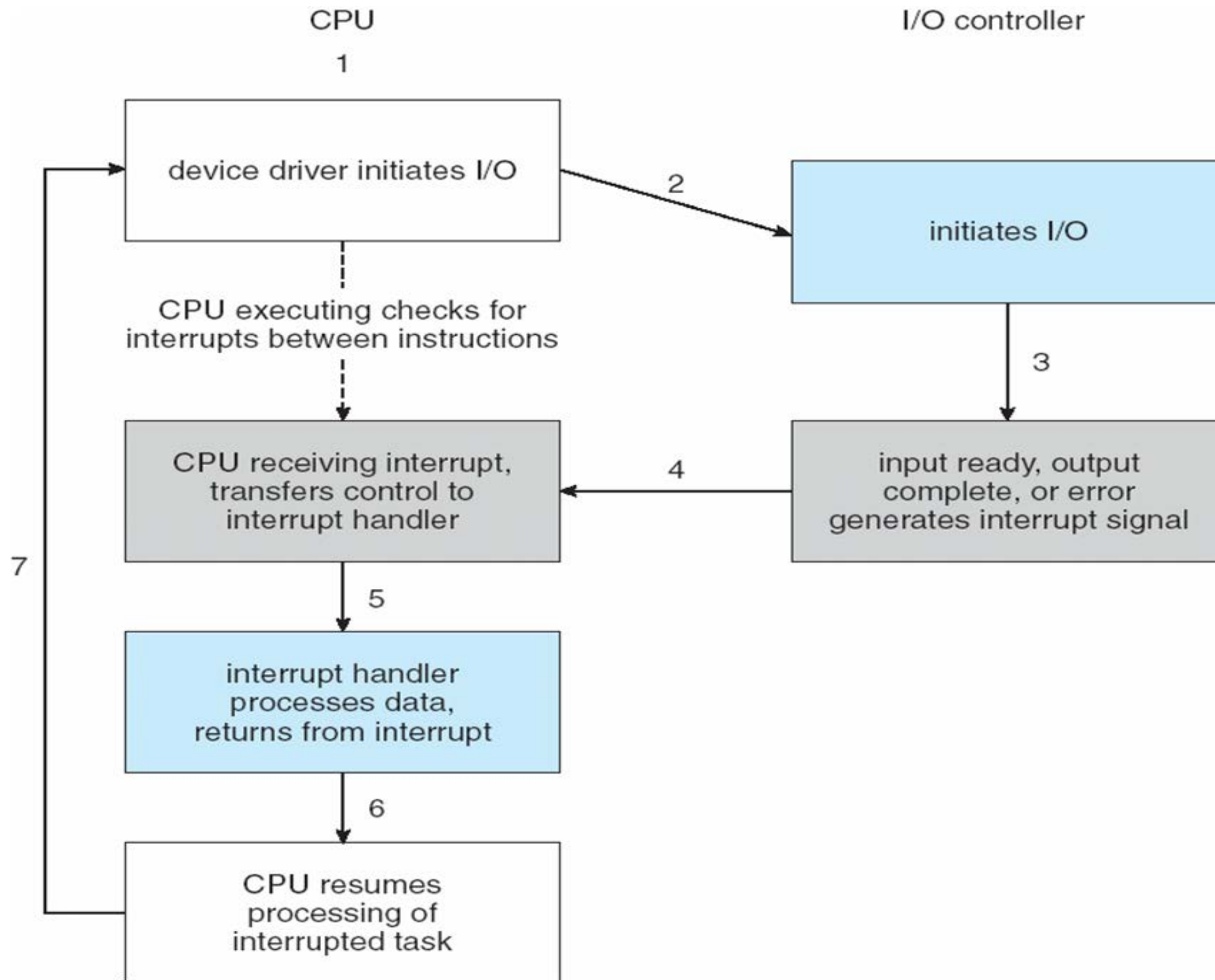



Intel Pentium Processor Event-Vector Table

vector number	description
0	divide error
1	debug exception
2	null interrupt
3	breakpoint
4	INTO-detected overflow
5	bound range exception
6	invalid opcode
7	device not available
8	double fault
9	coprocessor segment overrun (reserved)
10	invalid task state segment
11	segment not present
12	stack fault
13	general protection
14	page fault
15	(Intel reserved, do not use)
16	floating-point error
17	alignment check
18	machine check
19–31	(Intel reserved, do not use)
32–255	maskable interrupts





Interrupts (Cont.)

- Interrupt mechanism also used for **exceptions**
 - Terminate process, crash system due to hardware error
- Page fault executes when memory access error
- System call executes via **trap** to trigger kernel to execute request
- Multi-CPU systems can process interrupts concurrently
 - If operating system designed to handle it
- Used for time-sensitive processing, frequent, must be fast





Direct Memory Access

- Used to avoid **programmed I/O** (one byte at a time) for large data movement
- Requires **DMA** controller
- Bypasses CPU to transfer data directly between I/O device and memory
- OS writes DMA command block into memory
 - Source and destination addresses
 - Read or write mode
 - Count of bytes
 - Writes location of command block to DMA controller
 - Bus mastering of DMA controller – grabs bus from CPU
 - ▶ **Cycle stealing** from CPU but still much more efficient
 - When done, interrupts to signal completion
- Version that is aware of virtual addresses can be even more efficient - **DVMA**





Six Step Process to Perform DMA Transfer

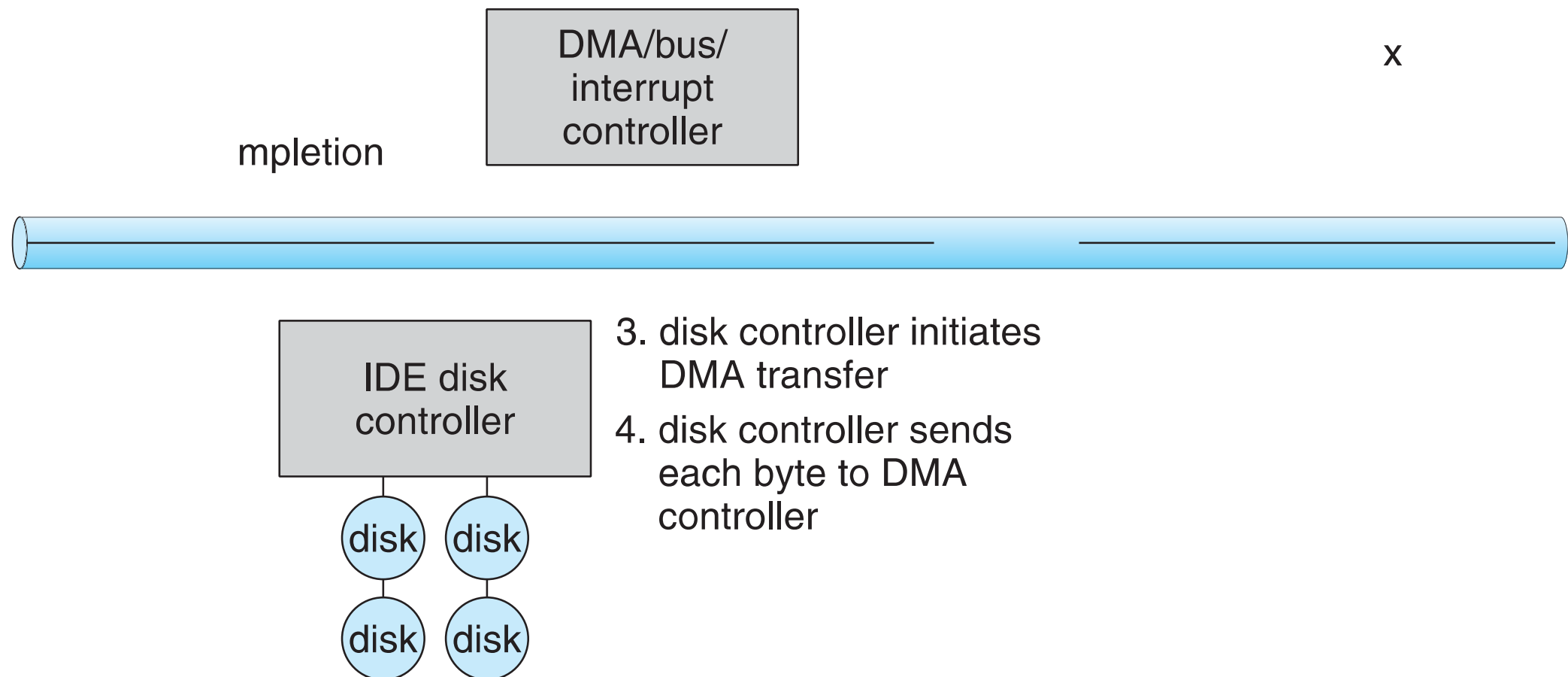



Application I/O Interface

- I/O system calls encapsulate device behaviors in generic classes
- Device-driver layer hides differences among I/O controllers from kernel
- New devices talking already-implemented protocols need no extra work
- Each OS has its own I/O subsystem structures and device driver frameworks
- Devices vary in many dimensions
 - **Character-stream** or **block**
 - **Sequential** or **random-access**
 - **Synchronous** or **asynchronous** (or both)
 - **Sharable** or **dedicated**
 - **Speed of operation**
 - **read-write, read only, or write only**





A Kernel I/O Structure

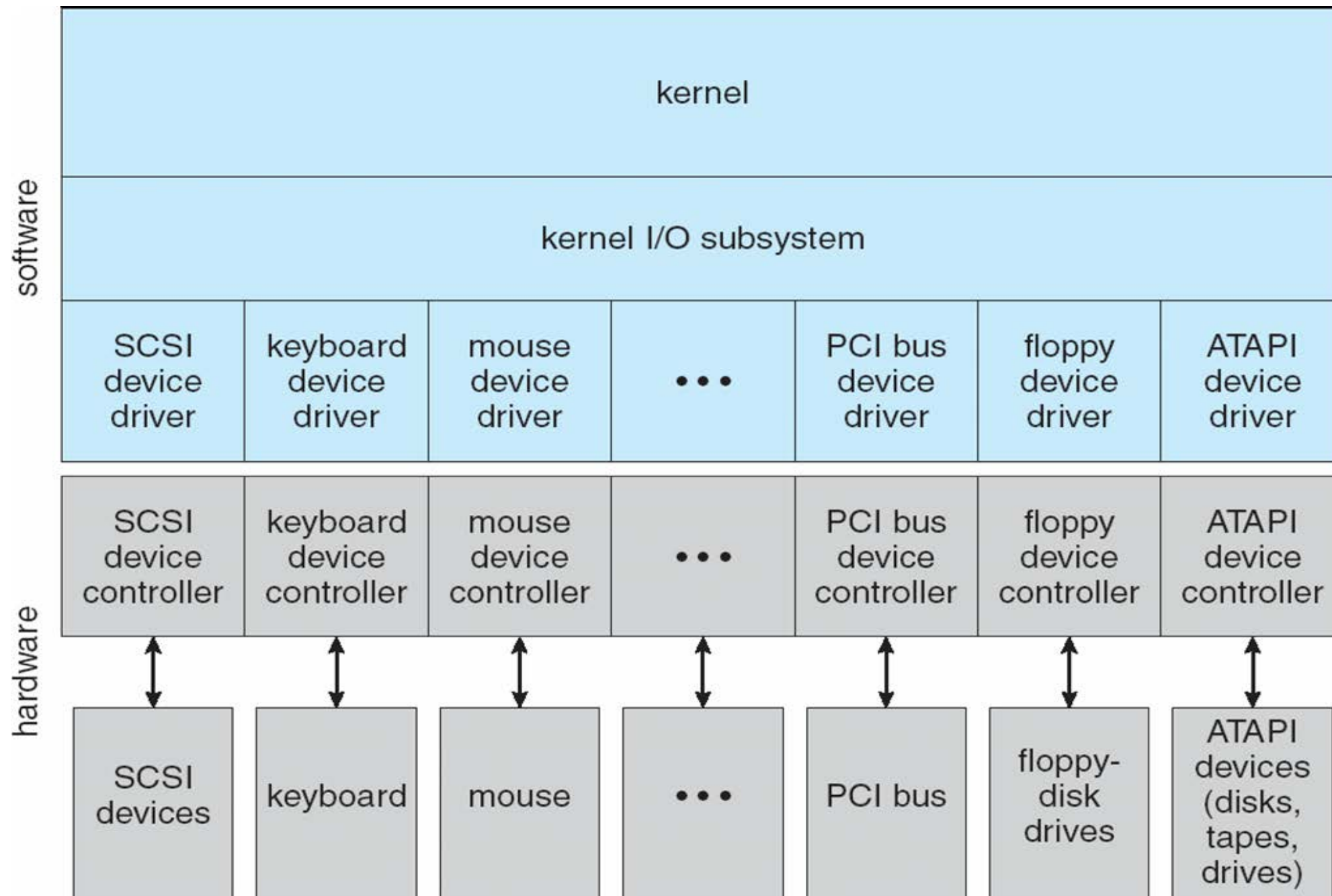



Characteristics of I/O Devices

aspect	variation	example
data-transfer mode	character block	terminal disk
access method	sequential random	modem CD-ROM
transfer schedule	synchronous asynchronous	tape keyboard
sharing	dedicated sharable	tape keyboard
device speed	latency seek time transfer rate delay between operations	
I/O direction	read only write only read–write	CD-ROM graphics controller disk





Characteristics of I/O Devices (Cont.)

- Subtleties of devices handled by device drivers

- Broadly I/O devices can be grouped by the OS into
 - Block I/O
 - Character I/O (Stream)
 - Memory-mapped file access
 - Network sockets

- For direct manipulation of I/O device specific characteristics, usually an escape / back door
 - Unix `ioctl()` call to send arbitrary bits to a device control register and data to device data register





Block and Character Devices

- Block devices include disk drives
 - Commands include read, write, seek
 - **Raw I/O**, **direct I/O**, or file-system access
 - Memory-mapped file access possible
 - ▶ File mapped to virtual memory and clusters brought via demand paging
 - DMA

- Character devices include keyboards, mice, serial ports
 - Commands include `get()`, `put()`
 - Libraries layered on top allow line editing





Network Devices

- Varying enough from block and character to have own interface
- Linux, Unix, Windows and many others include **socket** interface
 - Separates network protocol from network operation
 - Includes `select()` functionality
- Approaches vary widely (pipes, FIFOs, streams, queues, mailboxes)





Clocks and Timers

- Provide current time, elapsed time, timer
- Normal resolution about 1/60 second
- Some systems provide higher-resolution timers
- **Programmable interval timer** used for timings, periodic interrupts
- `ioctl()` (on UNIX) covers odd aspects of I/O such as clocks and timers





Nonblocking and Asynchronous I/O

- **Blocking** - process suspended until I/O completed
 - Easy to use and understand
 - Insufficient for some needs

- **Nonblocking** - I/O call returns as much as available
 - User interface, data copy (buffered I/O)
 - Implemented via multi-threading
 - Returns quickly with count of bytes read or written
 - `select()` to find if data ready then `read()` or `write()` to transfer

- **Asynchronous** - process runs while I/O executes
 - Difficult to use
 - I/O subsystem signals process when I/O completed





Two I/O Methods

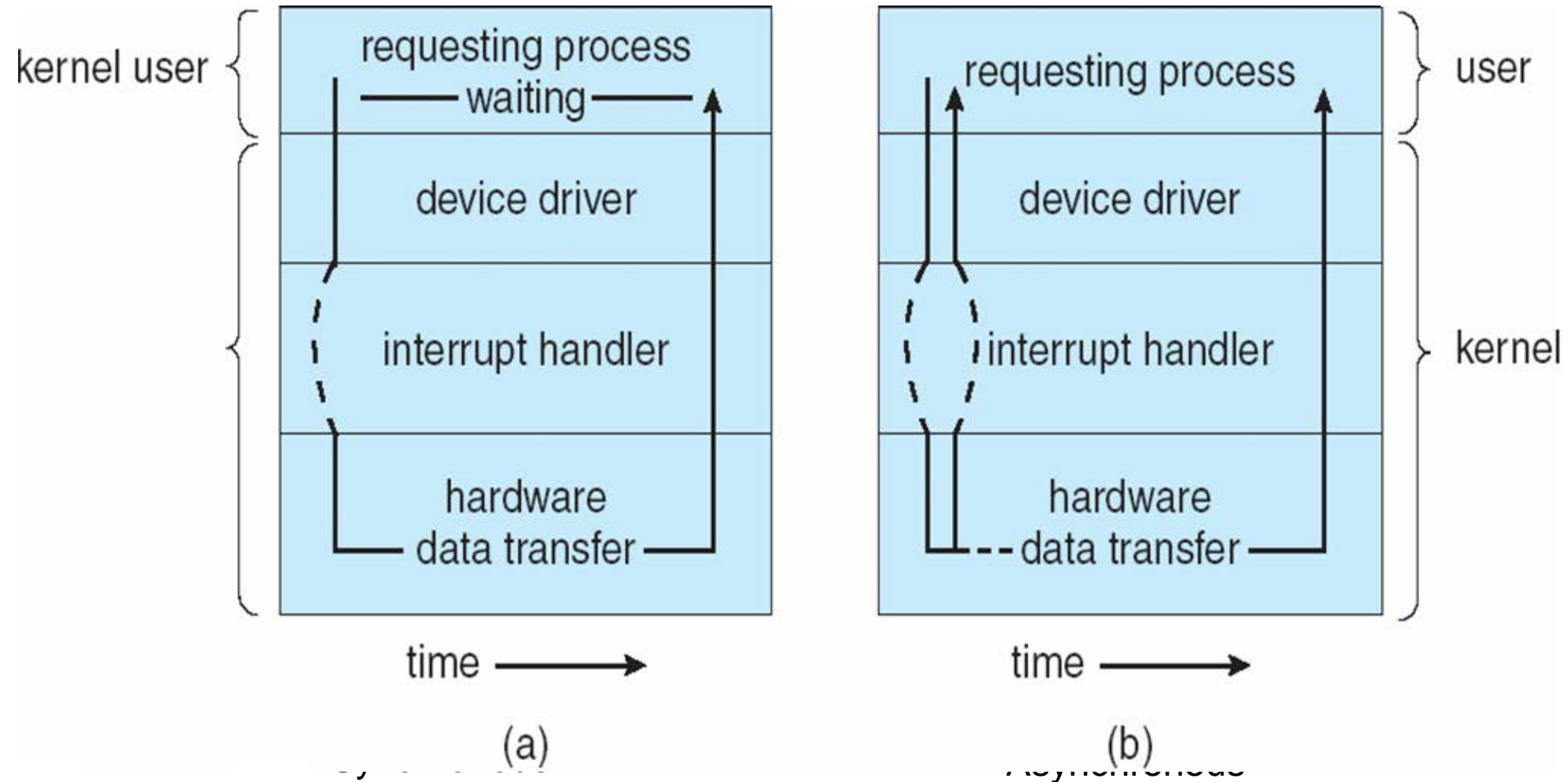



□□ Vectors I/O

- **Vectors I/O** allows one system call to perform multiple I/O operations
- For example, Unix `readve()` accepts a vector of multiple buffers to read into or write from
- This scatter-gather method better than multiple individual I/O calls
 - Decreases context switching and system call overhead
 - Some versions provide atomicity
 - ▶ Avoid for example worry about multiple threads changing data as reads / writes occurring





Kernel I/O Subsystem

- Scheduling
 - Some I/O request ordering via per-device queue
 - Some OSs try fairness
 - Some implement Quality Of Service (i.e. IPQOS)

- **Buffering** - store data in memory while transferring between devices
 - To cope with device speed mismatch
 - To cope with device transfer size mismatch
 - To maintain “copy semantics”
 - **Double buffering** – two copies of the data
 - ▶ Kernel and user
 - ▶ Varying sizes
 - ▶ Full / being processed and not-full / being used
 - ▶ Copy-on-write can be used for efficiency in some cases





Device-status Table

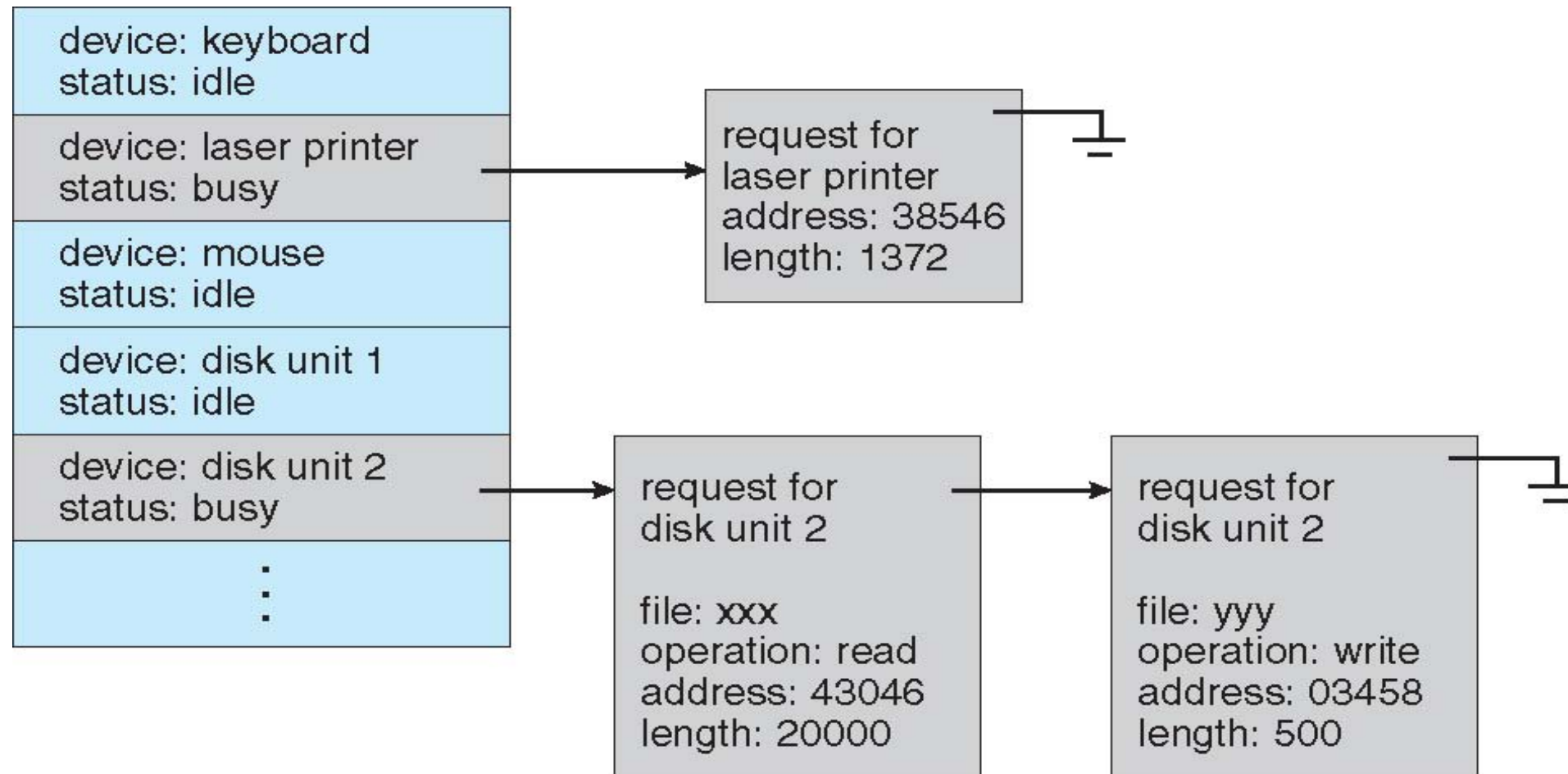



Sun Enterprise 6000 Device-Transfer Rates

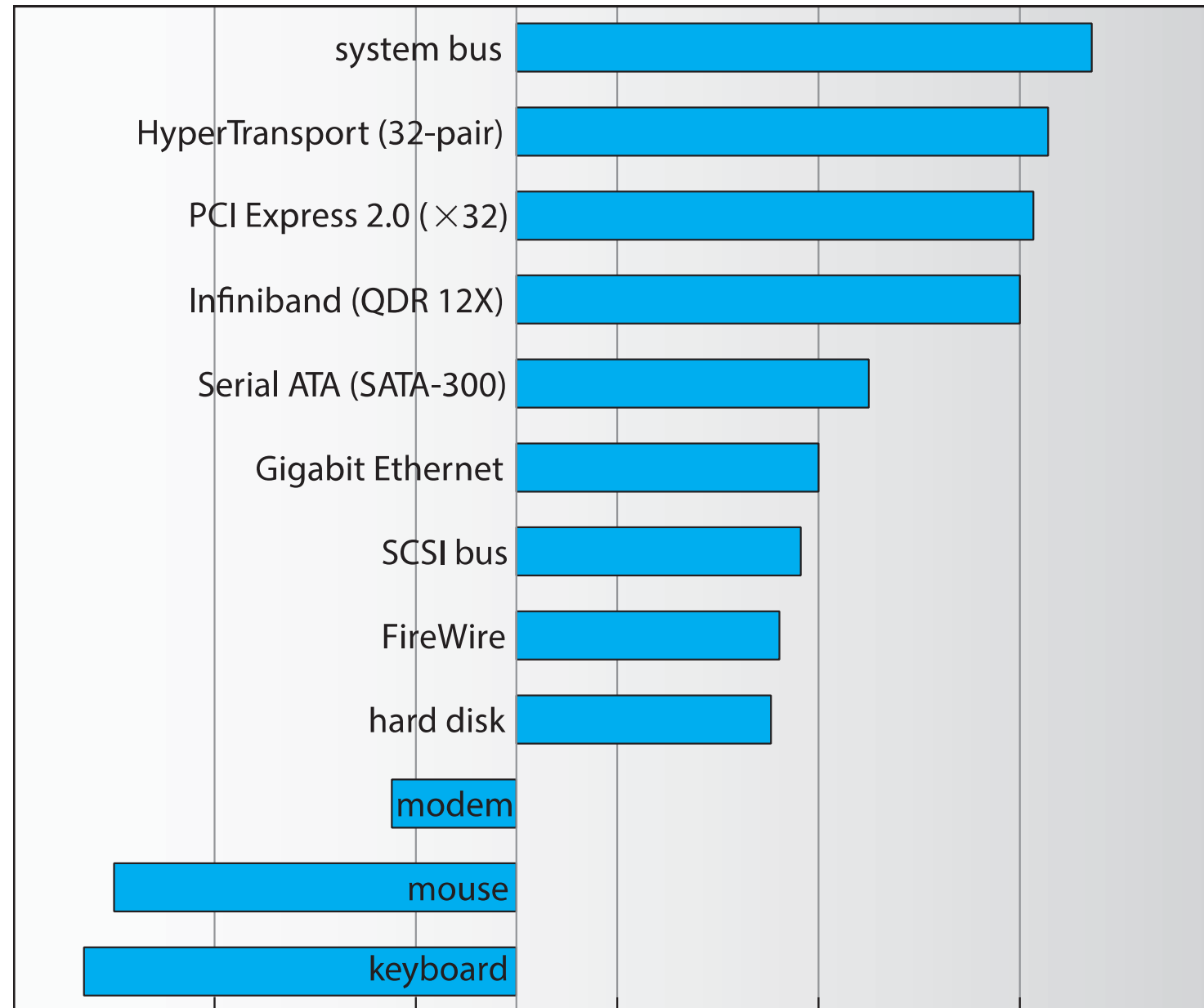



Kernel I/O Subsystem

- **Caching** - faster device holding copy of data
 - Always just a copy
 - Key to performance
 - Sometimes combined with buffering

- **Spooling** - hold output for a device
 - If device can serve only one request at a time
 - i.e., Printing

- **Device reservation** - provides exclusive access to a device
 - System calls for allocation and de-allocation
 - Watch out for deadlock





Error Handling

- OS can recover from disk read, device unavailable, transient write failures
 - Retry a read or write, for example
 - Some systems more advanced – Solaris FMA, AIX
 - ▶ Track error frequencies, stop using device with increasing frequency of retry-able errors
- Most return an error number or code when I/O request fails
- System error logs hold problem reports





I/O Protection

- User process may accidentally or purposefully attempt to disrupt normal operation via illegal I/O instructions
 - All I/O instructions defined to be privileged
 - I/O must be performed via system calls
 - ▶ Memory-mapped and I/O port memory locations must be protected too





Use of a System Call to Perform I/O

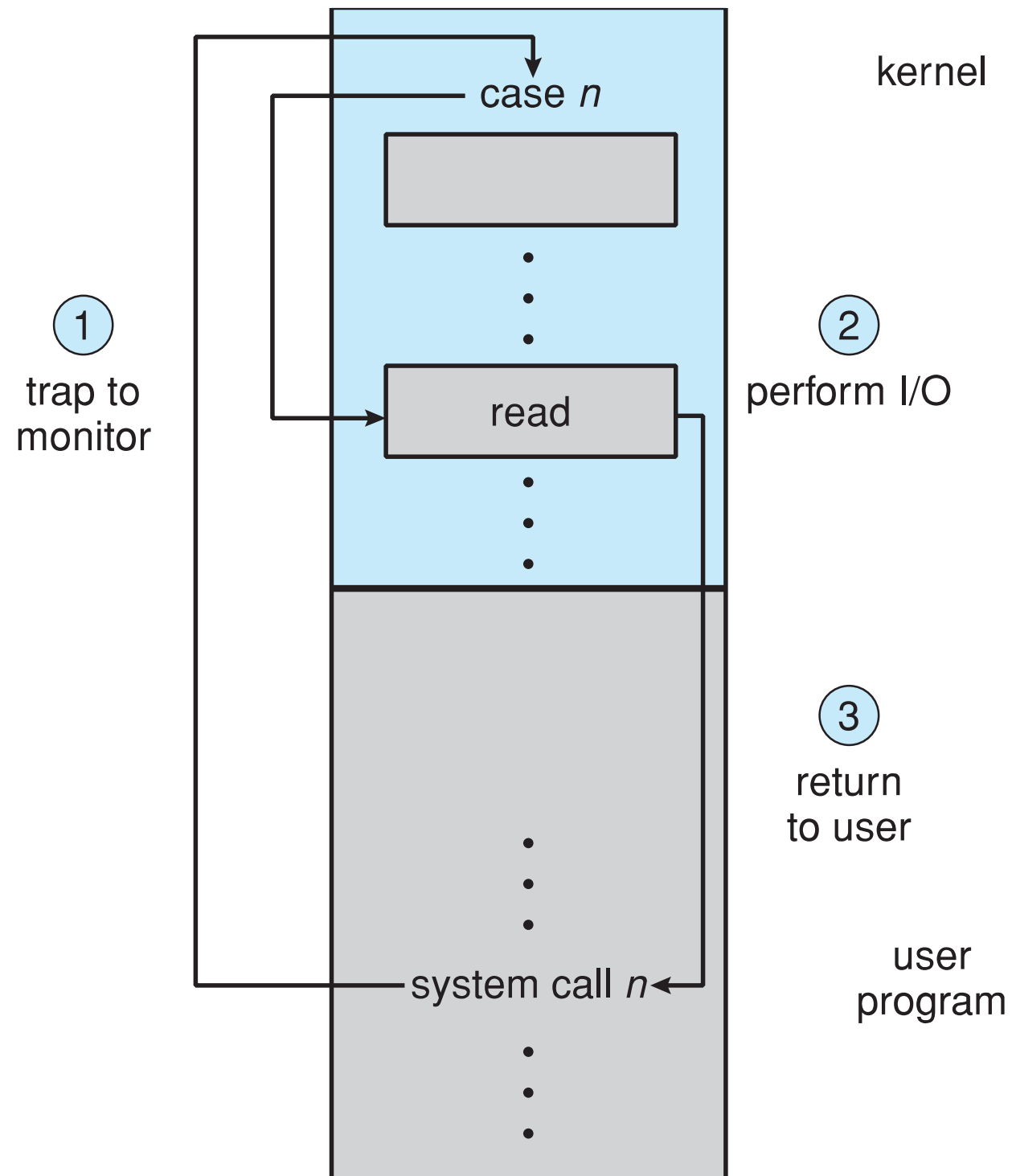



Kernel Data Structures

- Kernel keeps state info for I/O components, including open file tables, network connections, character device state
- Many, many complex data structures to track buffers, memory allocation, “dirty” blocks
- Some use object-oriented methods and message passing to implement I/O
 - Windows uses message passing
 - ▶ Message with I/O information passed from user mode into kernel
 - ▶ Message modified as it flows through to device driver and back to process
 - ▶ Pros / cons?





UNIX I/O Kernel Structure

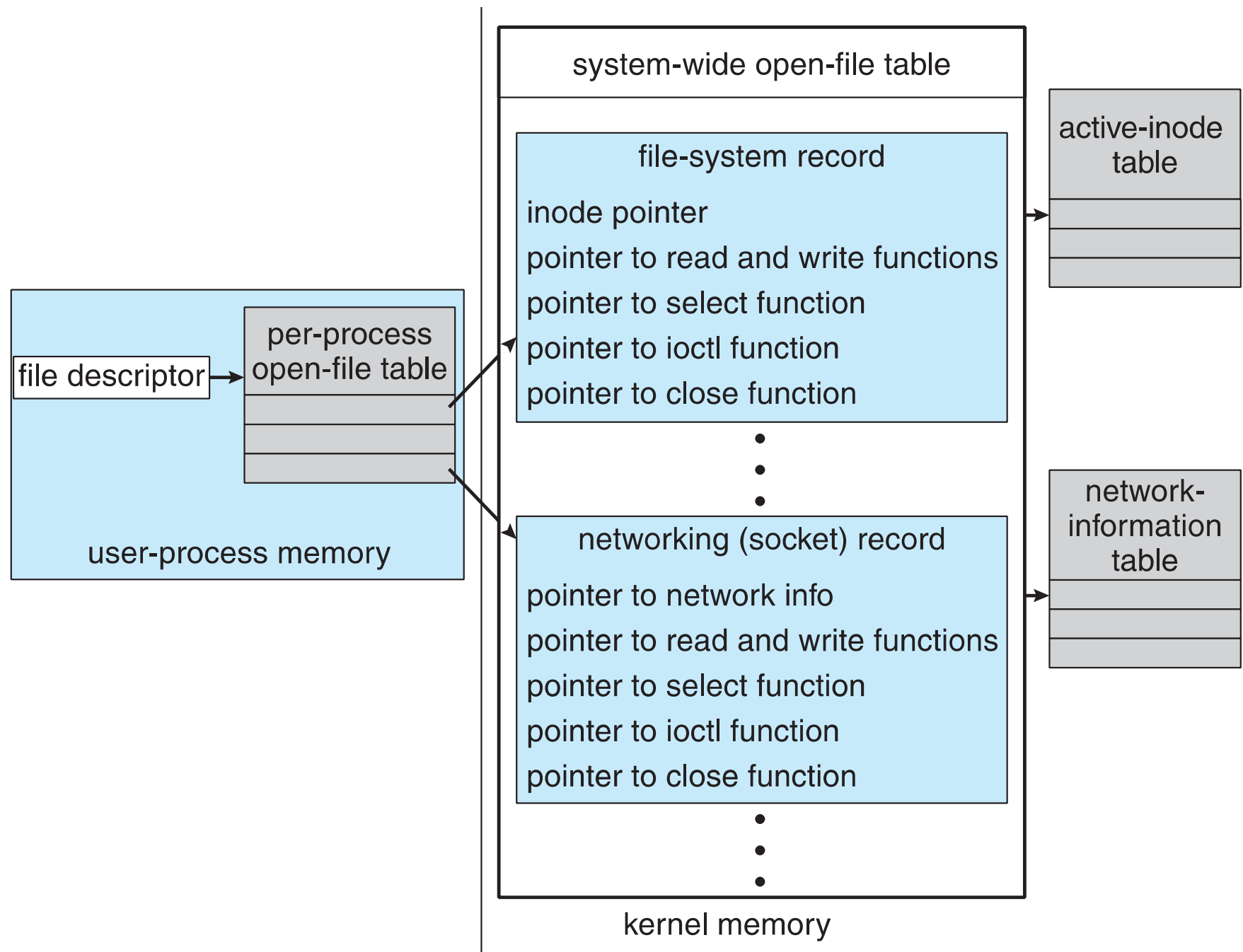



Power Management

- Not strictly domain of I/O, but much is I/O related
- Computers and devices use electricity, generate heat, frequently require cooling
- OSes can help manage and improve use
 - Cloud computing environments move virtual machines between servers
 - ▶ Can end up evacuating whole systems and shutting them down
- Mobile computing has power management as first class OS aspect
- For example, Android implements
 - Component-level power management
 - ▶ Understands relationship between components
 - ▶ Build device tree representing physical device topology
 - ▶ System bus -> I/O subsystem -> {flash, USB storage}
 - ▶ Device driver tracks state of device, whether in use
 - ▶ Unused component – turn it off
 - ▶ All devices in tree branch unused – turn off branch
 - Wake locks – like other locks but prevent sleep of device when lock is held
 - Power collapse – put a device into very deep sleep
 - ▶ Marginal power use
 - ▶ Only awake enough to respond to external stimuli (button press, incoming call)





I/O Requests to Hardware Operations

- Consider reading a file from disk for a process:
 - Determine device holding file
 - Translate name to device representation
 - Physically read data from disk into buffer
 - Make data available to requesting process
 - Return control to process





Life Cycle of An I/O Request

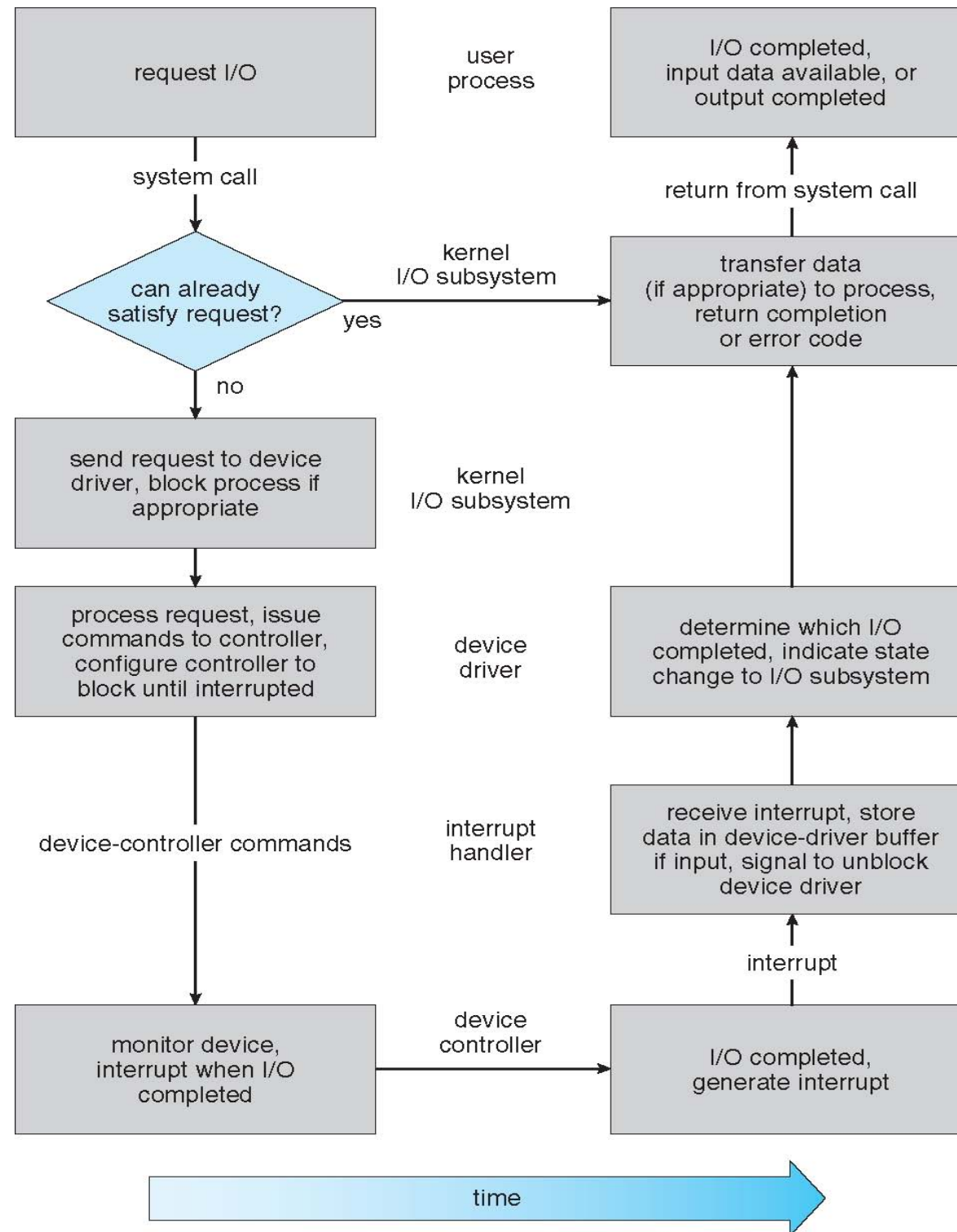



STREAMS

- **STREAM** – a full-duplex communication channel between a user-level process and a device in Unix System V and beyond

- A STREAM consists of:
 - STREAM head interfaces with the user process
 - driver end interfaces with the device
 - zero or more STREAM modules between them

- Each module contains a **read queue** and a **write queue**

- Message passing is used to communicate between queues
 - **Flow control** option to indicate available or busy

- Asynchronous internally, synchronous where user process communicates with stream head





The STREAMS Structure

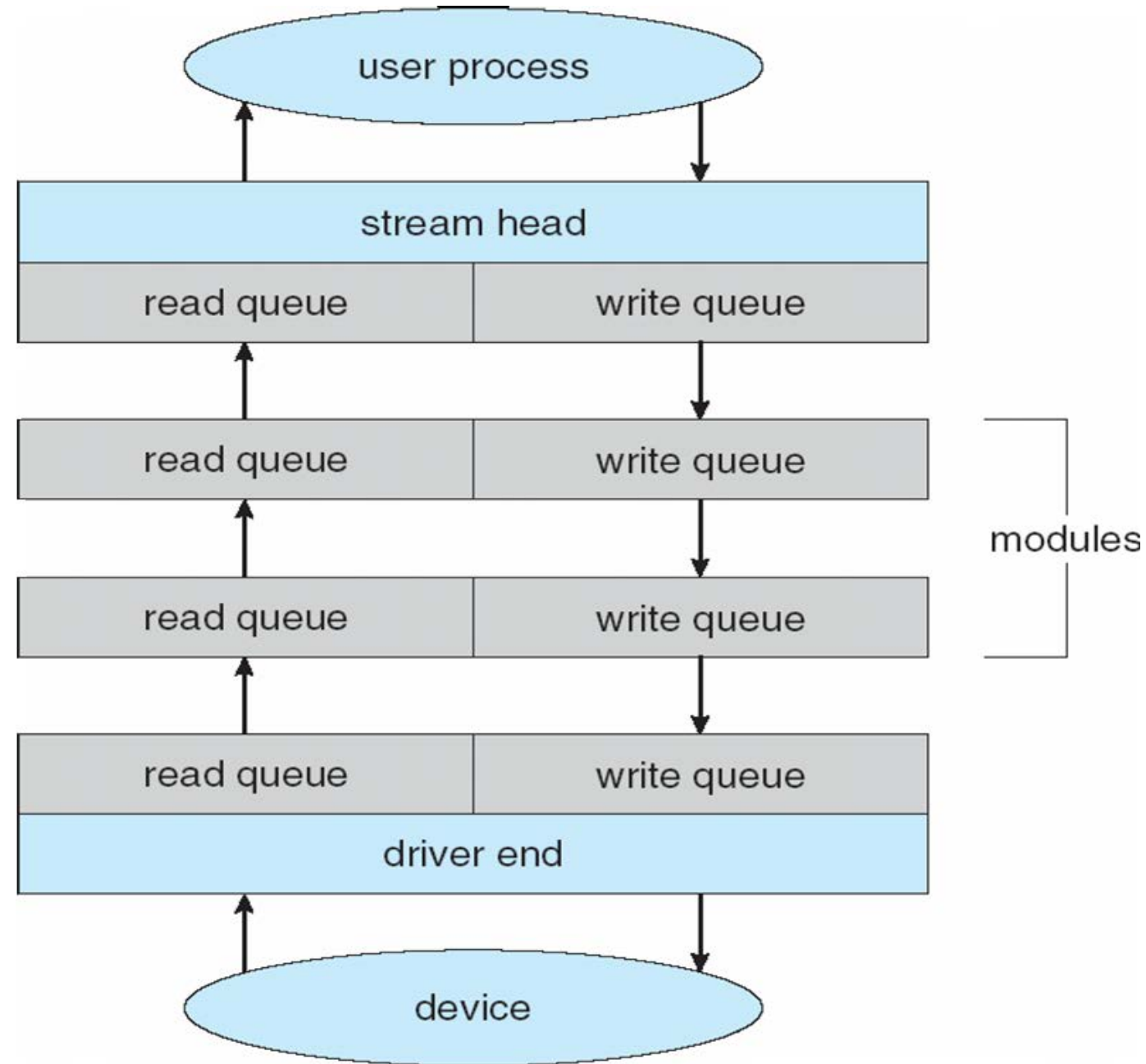



Performance

- I/O a major factor in system performance:
 - Demands CPU to execute device driver, kernel I/O code
 - Context switches due to interrupts
 - Data copying
 - Network traffic especially stressful





Intercomputer Communications

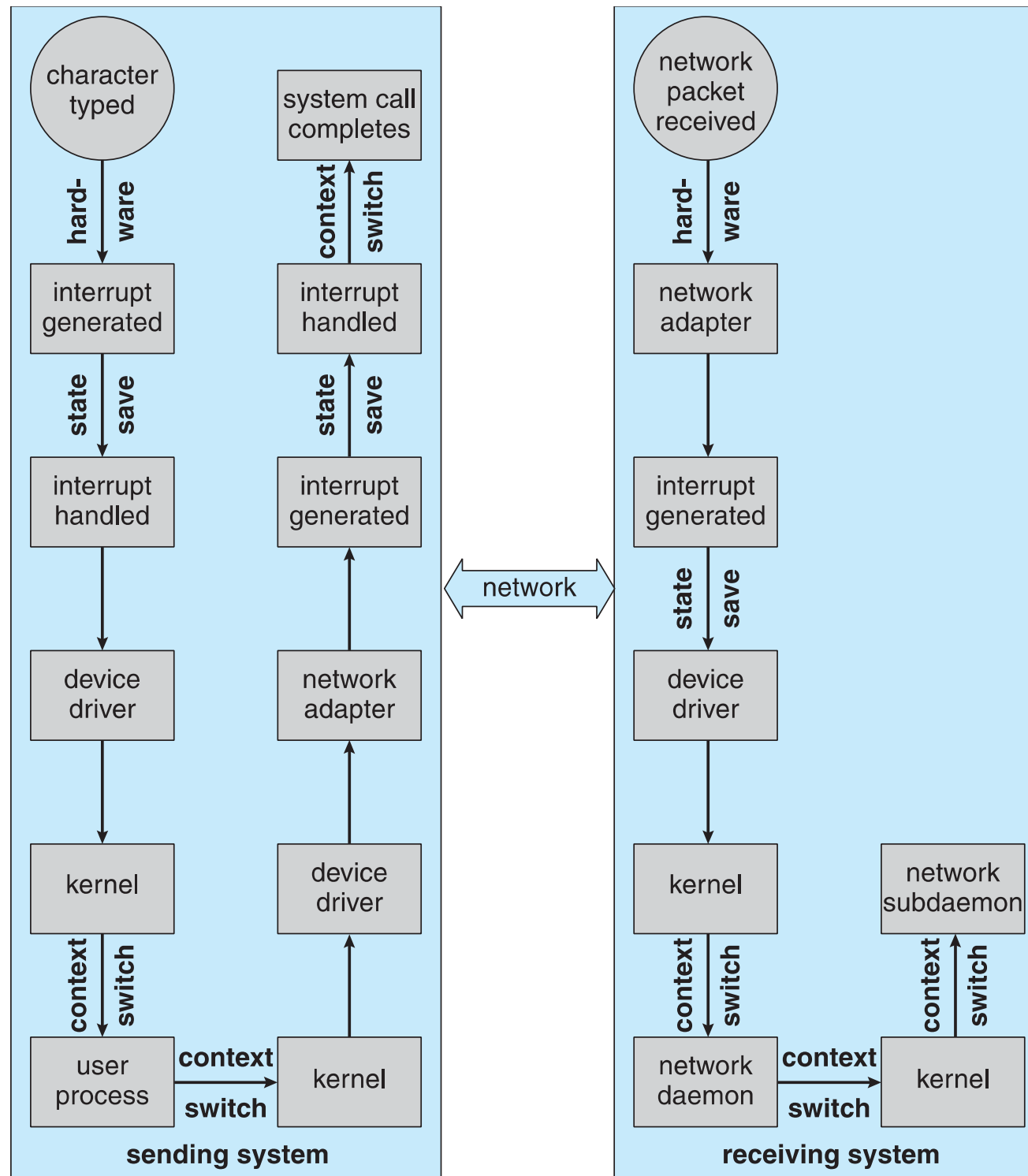



Improving Performance

- Reduce number of context switches
- Reduce data copying
- Reduce interrupts by using large transfers, smart controllers, polling
- Use DMA
- Use smarter hardware devices
- Balance CPU, memory, bus, and I/O performance for highest throughput
- Move user-mode processes / daemons to kernel threads





Device-Functionality Progression



End of Chapter 13

